

# HYDRAULIC POSITION AND MOTION CONTROL SOLUTIONS



# CONTENTS

---

ABOUT POWER-PACKER .....	5
STANDARD HYDRAULIC STABILIZATION LEGS .....	6
HEAVY-DUTY HYDRAULIC STABILIZATION LEGS .....	11
HYDRAULIC CYLINDERS .....	14
HYDRAULIC LATCHES .....	18
CAB SUSPENSION .....	22
HYDRAULIC PUMPS .....	25
VALVE ASSEMBLIES & CONTROL BOXES .....	29

***POWER-PACKER***<sup>®</sup>



[powerpacker.us.com](http://powerpacker.us.com)



# THE POWER-PACKER DIFFERENCE

## MANUFACTURING LOCATION



Wisconsin, USA  
516 Hillcrest Drive  
Westfield, WI 53964

# ABOUT POWER-PACKER

## 50 YEARS OF INNOVATION

For more than five decades, we've engineered a robust and innovative line of hydraulic position and motion control products and systems that have become the gold standard for tilting, latching, leveling and stabilizing systems in on- and off-highway markets.

## PROGRESS IN MOTION



**Seamless integration.** We design our products to create easy, effortless integration for you and your customers.



**Proven performance.** Every product and solution must meet our rigorous quality standards to ensure reliability and optimal performance.



**Added value.** Our goal is to help you, your employees and customers work smarter, safer and more efficiently.



**Unparalleled expertise.** Rely on our expertise in hydraulic position and motion control to help deliver superior equipment to your end user.

## WHO WE ARE

We're a team of experienced professionals dedicated to understanding the precision hydraulic system needs of the many markets our customers work in, including military, construction, oil and gas, mining, heavy-duty truck and trailer, fire and rescue, and medical. Through our deep technical knowledge, we strive to anticipate your future needs and design innovative products to meet them.



## WHAT WE DO

We make hard-working, hydraulic position and motion control systems that are built to ISO9001 standards. Whether your project requires lifting a heavy load, supporting a packed trailer, locking a drill mast in position or stabilizing a utility truck, our team delivers personalized, timely service. No matter how simple, complex or unique your needs may be, our goal is to always give you high-quality, long-lasting and safe systems that consistently stand up to the most rigorous demands.

# STANDARD HYDRAULIC STABILIZATION LEGS



## Stabilize your on- and off-highway equipment

Selecting the right stabilization leg is critical to keep your equipment safely and securely in place. We offer standard stabilization legs with several optional features based on your application. Whether you're moving goods and equipment between locations or transporting heavy equipment to a portable worksite, we'll help you incorporate the best Power-Packer products into your stabilization

## On-highway applications: Upgrade your stabilization system

Stabilization legs can be damaged during on-highway travel if they're not fully retracted. Upgrade your stabilization system with Power-Packer's hydraulic stabilization legs, now designed with proximity sensor capabilities. Increase longevity, optimize efficiency and avoid costly downtime. Adding a proximity sensor to your stabilization legs gives you the ability to indicate to operators when the hydraulic stabilization or jack legs are fully retracted and it's safe to move on to the next

## Off-highway applications: Choose standard, stiff legs

Stabilize run-on, off-highway projects, like permanent or portable rock crushers, screen plants or power generation equipment with our standard, stiff stabilization legs. Similar in capacity to a standard leg, stiff stabilization legs offer added strength from mechanical locking pins.

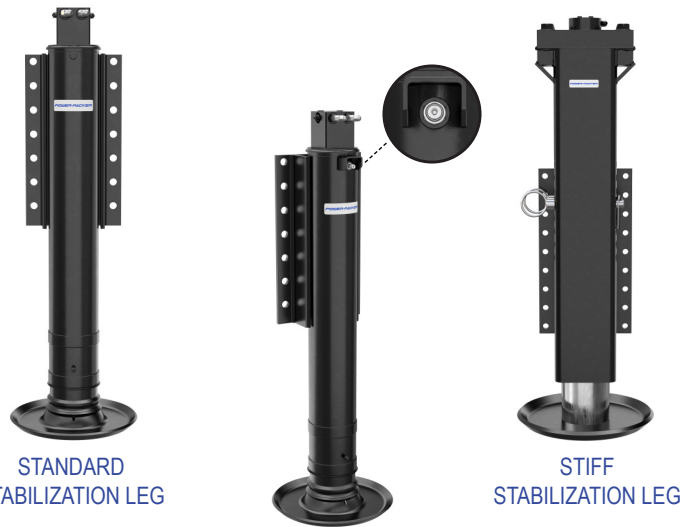

STANDARD STABILIZATION LEG

STABILIZATION LEG WITH OPTIONAL PROXIMITY SENSOR

STIFF STABILIZATION LEG

### STANDARD LEG OVERVIEW FOR UP TO 70,000 LB. CAPACITY

#### LIFT, LOWER AND HOLD

Raise equipment to the desired height to safely complete the work. Easily lower equipment to quickly move to the next project. Reliably hold equipment in place throughout duration of operation, even during extended periods of use.

#### LEVEL

Level equipment in virtually any environment, even rugged conditions.

#### STABILIZE

Wider stabilization shoes ensure stability, preventing tipping during use of equipment.

## STANDARD HYDRAULIC STABILIZATION LEGS

Power-Packer's full line of hydraulic stabilization legs are designed to deliver superior performance, allowing for a more efficient, reliable and safe working environment. This product line offers several options:

- 3-, 3.5-, 4-, 5- and 6-inch bores
- 18- to 36-inch stroke
- 16,000- to 70,000-pound leg capacity
- Up to 7,000-pound side load capacity
- 10-, 12- or 16-inch swivel shoes, moving in all directions, plus or minus 5 degrees
- 8.38-, 10.63- or 16-inch mounting plates
- 5 gpm (3-inch bore), 3 gpm (3.5- or 4-inch bore), 15 gpm (5- or 6-inch bore) maximum flow rates
- Upgrade to stiff stabilization legs: Mechanical locking pins at 0.375-inch intervals give legs added stability.
- Choose proximity sensing: Add proximity sensing capabilities to many of our hydraulic legs. Two settings available, normally open or normally closed, depending on preferred control logic.

## Why Choose Power-Packer Hydraulic Stabilization Legs

### SAE fittings

Reduce potential leaks.

### Integrated valve block

Decreases assembly time. Eliminates potential for catastrophic failure and repair costs with positive load holding, even if a line, tube or fittings are damaged or disconnected while leg is under load.

### Mounting plate

Simplifies installation. Optional matching mounting plates save time spent drilling and matching mount on new or retrofit applications.

### Counter-balance valve

Provides overload protection when lifting an unbalanced load.

### Proximity sensor

Increases leg longevity, optimizes efficiency and helps avoid costly downtime.

### Tube-in-tube design

Extends cylinder life. The design isolates rod and seal from damage by rock, dust or debris.

### Multiple shoe types

Shoes available in swivel, fixed or ball end for added flexibility.

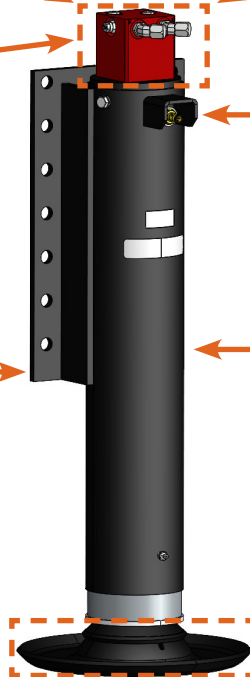

# STANDARD HYDRAULIC STABILIZATION LEGS

Stabilization Leg – 3 in. (76 mm) bore – Load Capacity of 16,000 lbs. or 71.2 kN										
Part No.	Stroke (SL)		Mounting Height (MH)		Shoe Diameter (SD)		Shoe Type	Weight		Valve Type
	in.	mm	in.	mm	in.	mm		lbs.	kg	
2010-18	18.0	457	25.0	635	10.0	254	Swivel	73	33.11	PO Check
2012-25	25.0	635	32.5	826	10.0	254	Swivel	92	41.73	PO Check
2014-18	18.0	457	25.0	635	10.0	254	Swivel	54	24.49	PO Check
2027-18	18.0	457	25.0	635	10.0	254	Swivel	75	34.02	PO Check
3510000108	18.0	457	26.6	676	10.0	254	Swivel	85	38.56	PO Check
3510000265	25.0	635	23.5	597	10.0	254	Swivel	105	47.63	PO Check
Stabilization Leg – 3.5 in. (89 mm) bore – Load Capacity 24,000 lbs. or 106.8 kN										
101457	25.5	648	12.75	324	16.0	406	Swivel	100	45.36	PO Check
101527-ES	15.0	381	20.25	514	10.0	254	Fixed	85	38.56	PO Check
300071	15.0	381	24.75	629	10.0	254	Fixed	85	38.56	PO Check
300072	16.5	419	26.25	667	10.0	254	Fixed	90	40.82	PO Check
300073	19.0	483	29.25	743	10.0	254	Fixed	95	43.09	PO Check
300074	20.0	508	29.65	753	12.0	305	Swivel	100	45.36	PO Check
300075	20.0	508	34.5	876	12.0	305	Swivel	100	45.36	PO Check
300076	24.0	610	33.5	851	12.0	305	Swivel	115	52.16	PO Check
300553-ES	24.0	610	34.5	876	12.0	305	Swivel	115	52.16	PO Check
300554-ES	20.0	508	29.5	749	12.0	305	Swivel	100	45.36	PO Check
300575-ES	29.5	749	13.5	343	12.0	305	Swivel	135	61.23	PO Check
300578-ES	20.0	508	25.5	648	12.0	305	Swivel	110	49.90	PO Check
9010000690	14.5	368	25.0	635	16.0	406	Fixed	100	45.36	PO Check
300666	25.5	648	12.75	324	16.0	406	Swivel	100	45.36	PO Check
3510000014	34.5	876	12.75	324	16.0	406	Swivel	145	65.77	PO Check
3510000260	35.0	889	12.75	324	16.0	406	Swivel	150	68.04	PO Check
9010000869	16.0	406	23.75	603	10.0	254	Fixed	95	43.09	DCBV
9010001153	24.0	610	14.4	366	Knuckle		Ball End	105	47.63	DCBV
9010001233	24.25	616	23.75	603	12.0	305	Swivel	110	49.90	PO Check
9010001296	22.5	572	28.5	724	12.0	305	Swivel	105	47.63	DCBV
9010001305	22.5	572	22.5	572	12.0	305	Swivel	105	47.63	DCBV
Proximity Equipped Leg – 3.5 in. (89 mm) bore										
9010001520	15.0	381	24.75	629	10.0	254	Fixed	85	38.56	PO Check
9010001521	20.0	508	29.65	753	12.0	305	Swivel	100	45.36	PO Check
9010001522	20.0	508	25.5	648	12.0	305	Swivel	110	49.90	PO Check
9010001523	24.0	610	14.4	366	Knuckle		Ball End	105	47.63	DCBV
9010001524	24.0	610	34.5	876	12.0	305	Swivel	115	52.16	PO Check
9010001525	25.5	648	12.75	324	16.0	406	Swivel	100	45.36	PO Check
9010001526	29.5	749	13.5	343	12.0	305	Swivel	135	61.23	PO Check
9010001527	34.5	876	12.75	324	16.0	406	Swivel	145	65.77	PO Check
Stiff Leg – 3.5 in. (89 mm) bore										
300634	20.5	521	29.5	749	12.0	305	Swivel	110	49.90	PO Check
300635	20.5	521	29.5	749	12.0	305	Swivel	110	49.90	PO Check
300671	20.5	521	29.5	749	12.0	305	Swivel	110	49.90	PO Check
300672	20.5	521	29.5	749	12.0	305	Swivel	110	49.90	PO Check



# STANDARD HYDRAULIC STABILIZATION LEGS

Stabilization Leg – 4 in. (102 mm) bore – Load Capacity 31,000 lbs. or 137.9 kN										
Part No.	Stroke (SL)		Mounting Height (MH)		Shoe Diameter (SD)		Shoe Type	Weight		Valve Type
	in.	mm	in.	mm	in.	mm		lbs.	kg	
9010000795	36.0	914	30.0	761	12.0	305	Swivel	170	77.11	DCBV
9010000807	20.5	521	29.9	760	12.0	305	Swivel	160	72.57	DCBV
9010000814	24.5	622	29.8	756	12.0	305	Swivel	125	56.70	DCBV
9010000815	36.0	914	29.5	749	12.0	305	Swivel	165	74.84	DCBV
9010000816	25.5	648	13.0	330	16.0	406	Swivel	150	68.04	DCBV
9010000817	36.0	914	26.7	677	16.0	406	Swivel	185	83.91	DCBV
9010000818	24.5	622	33.9	860	12.0	305	Swivel	135	61.23	DCBV
9010000822	36.0	914	35.4	898	12.0	305	Swivel	170	77.11	DCBV
9010000824	36.0	914	19.4	491	12.0	305	Swivel	170	77.11	DCBV
9010000862	14.8	375	24.8	629	10.0	254	Fixed	105	47.63	DCBV
9010000864	16.5	419	28.0	711	12.0	305	Swivel	110	49.90	DCBV
9010000874	36.0	914	20.0	508	12.0	305	Swivel	170	77.11	DCBV
9010000885	36.0	914	35.9	912	16.0	406	Swivel	190	86.18	DCBV
9010000893	36.0	914	31.9	811	16.0	406	Swivel	190	86.18	DCBV
9010000894	20.5	521	30.4	772	16.0	406	Swivel	185	83.91	DCBV
9010001038	19.5	495	29.3	743	10.0	254	Fixed	115	52.16	DCBV
9010001133	14.8	375	19.0	482	10.0	254	Fixed	105	47.63	DCBV
9010001140	36.0	914	27.5	699	12.0	305	Swivel	170	77.11	DCBV
9010001159	24.5	622	22.0	558	12.0	305	Swivel	130	58.97	DCBV
9010001181	36.0	914	29.0	737	16.0	406	Swivel	200	90.72	DCBV
9010001263	48.0	1219	19.7	500	16.0	406	Swivel	235	106.59	DCBV
9010001264	16.0	406	18.5	470	10.0	254	Fixed	110	49.90	DCBV
9010001288	36.0	914	30.8	781	16.0	406	Swivel	190	86.18	DCBV
9010001327	36.0	914	45.9	1166	16.0	406	Swivel	190	86.18	DCBV
Proximity Equipped Leg – 4 in. (102 mm) bore										
9010001497	20.5	521	29.9	760	12.0	305	Swivel	160	72.57	DCBV
9010001528	14.8	375	24.8	629	10.0	254	Fixed	105	47.63	DCBV
9010001529	16.5	419	28.0	711	12.0	305	Swivel	110	49.90	DCBV
9010001531	24.5	622	22.0	558	12.0	305	Swivel	130	58.97	DCBV
9010001532	24.5	622	33.9	860	12.0	305	Swivel	135	61.23	DCBV
9010001533	25.5	648	13.0	330	16.0	406	Swivel	150	68.04	DCBV
9010001534	36.0	914	30.0	761	12.0	305	Swivel	170	77.11	DCBV
Stiff Leg – 4 in. (102 mm) bore										
9010000804	20.5	521	29.9	760	12.0	305	Swivel	160	72.57	DCBV
9010000805	20.5	521	29.9	760	12.0	305	Swivel	160	72.57	DCBV
9010000806	20.5	521	29.9	760	12.0	305	Swivel	160	72.57	DCBV
9010000813	20.5	521	29.9	760	12.0	305	Swivel	170	77.11	DCBV
9010000819	24.5	622	33.9	860	12.0	305	Swivel	170	77.11	DCBV
9010000825	36.0	914	30.0	761	12.0	305	Swivel	190	86.18	DCBV
9010000826	16.0	406	26.4	670	10.5	267	Fixed	145	65.77	DCBV
9010000827	16.0	406	26.4	670	10.5	267	Fixed	145	65.77	DCBV
9010000854	24.5	622	34.9	885	12.0	305	Swivel	175	79.38	DCBV

# STANDARD HYDRAULIC STABILIZATION LEGS

Stiff Leg – 4 in. (102 mm) bore										
Part No.	Stroke (SL)		Mounting Height (MH)		Shoe Diameter (SD)		Shoe Type	Weight		Valve Type
	in.	mm	in.	mm	in.	mm		lbs.	kg	
9010001146	15.5	394	13.0	330	12.0	305	Swivel	110	49.90	DCBV
9010001150	15.5	394	13.0	330	12.0	305	Swivel	110	49.90	DCBV
9010001211	24.5	622	23.6	599	12.0	305	Swivel	170	77.11	DCBV
Stabilization Leg – 5 in. (127 mm) bore - Load Capacity of 49,000 lbs. or 218 kN										
300463-ES	18.0	457	19.7	500	16.0	406	Swivel	275	124.74	PO Check
300464-ES	24.0	610	19.5	495	16.0	406	Swivel	340	154.22	PO Check
300465-ES	36.0	914	19.5	495	16.0	406	Swivel	375	170.10	PO Check
300487-ES	18.0	457	24.0	610	16.0	406	Swivel	340	154.22	PO Check
300488-ES	24.0	610	24.4	618	16.0	406	Swivel	350	158.76	PO Check
300490-ES	36.0	914	24.0	610	16.0	406	Swivel	500	226.80	PO Check
300491-ES	48.0	1219	24.0	610	16.0	406	Swivel	600	272.16	PO Check
300518-ES	24.0	610	24.0	610	16.0	406	Swivel	400	181.44	PO Check
9010000605	48.0	1219	19.5	495	16.0	406	Swivel	600	272.16	PO Check
9010000642	36.0	914	19.5	495	16.0	406	Swivel	370	167.83	PO Check
9010001078	24.0	610	24.3	617	16.0	406	Swivel	390	176.90	DCBV
9010001079	36.0	914	19.9	505	16.0	406	Swivel	375	170.10	DCBV
9010001080	18.0	457	19.9	505	16.0	406	Swivel	375	170.10	DCBV
9010001077	24.0	610	24.3	617	10.5	267	Swivel	350	158.76	DCBV
9010001160	36.0	914	33.0	838	16.0	406	Swivel	390	176.90	PO Check
9010001277	24.0	610	20.5	521	10.5	267	Swivel	340	154.22	DCBV
9010001297	36.0	914	34.9	887	16.0	406	Swivel	390	176.90	DCBV
Stabilization Leg – 6 in. (152 mm) bore - Load Capacity of 70,000 lbs. or 311.4 kN										
300050	18.0	457	27.3	693	16.0	406	Swivel	270	122.47	PO Check
300084	24.0	610	27.4	696	16.0	406	Swivel	300	136.08	PO Check
300137-ES	36.0	914	27.3	693	16.0	406	Swivel	360	163.29	PO Check
9010001076	24.0	610	27.5	699	16.0	406	Swivel	350	158.76	DCBV
9010001082	36.0	914	27.5	699	16.0	406	Swivel	420	190.51	DCBV
Stiff Leg – 6 in. (152 mm) bore										
300184-ES	18.0	457	27.8	705	16.0	406	Swivel	530	240.40	PO Check
300431-ES	24.0	610	28.0	711	16.0	406	Swivel	560	254.01	PO Check
300439-ES	36.0	914	27.8	705	16.0	406	Swivel	660	299.37	PO Check
9010001075	36.0	914	28.0	711	16.0	406	Swivel	660	299.37	DCBV

Proximity Sensor Kit	
Part No.	Part Name
1010003864	Kit, Proximity Switch Normally Open (NO) with Cable
1010003865	Kit, Proximity Switch Normally Closed (NC) with Cable

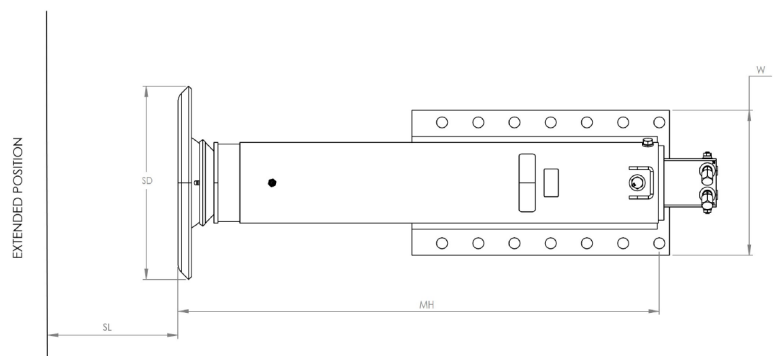

# HEAVY-DUTY HYDRAULIC STABILIZATION LEGS



## Power, performance and reliability for the toughest applications

Safely support and level a wide range of the most rugged equipment in the toughest work environments. Our heavy-duty stabilization legs arrive completely assembled and tested with a bolt-on, outer tube mount conveniently integrated into the design.

### HEAVY-DUTY LEG OVERVIEW FOR UP TO 85,000LB LEG CAPACITY

#### LARGER CAPACITY

Heavy-duty stabilization legs offer greater lift capacity and mechanical load holding. Depending on the stroke size HD Stabilization legs offer 10 to 20% additional side load capacity.

#### RUGGED ALL-WEATHER DESIGN

Designed to withstand all temperatures, including extreme cold, heavy-duty legs have a dual cylinder guide ring to help keep external contaminants out and offer lateral stability. The durable locknut construction also provides solid support.

#### ENHANCED PRODUCTIVITY

The flexible design allows you to optimize your in-house processes. The legs are shipped complete, with no assembly process required.

#### IMPROVED SAFETY

Integrated dual counterbalance valves eliminate potential catastrophic failures when the valve is remotely located. The relieving function ensures the heavy-duty legs have positive load holding in case of pressure loss.



## HEAVY-DUTY HYDRAULIC STABILIZATION LEGS

Our Heavy-Duty Hydraulic Stabilization Leg product line offers several options:

- 5- and 6-inch bore options
- 12-, 18-, 24- and 36-inch stroke options
- 58,000 to 85,000-pound leg capacity
- 170,000-pound mechanical load holding
- 0 to 20% side-load capacity
- 14- and 20-degree swivel shoe options
- 11- and 25.5-inch mounting plate option
- 5 gpm maximum flow rate

## Why Choose Power-Packer Heavy-Duty Stabilization Legs

### Integrated valve block/dual counterbalance valves

Provides overload protection and positive load holding in case of damage or disconnection while the leg is under load.

### Dual guide rings

Located inside an outer-mount tube to offer side load advantage and save on wear.

### Infinitely adjustable stiff leg

Allows for maximum safety and flexibility.



**Two different back mounting plate options**  
Allow for ease of attachment.

**Removable footpads available**

# HEAVY-DUTY STABILIZATION LEGS

Heavy-Duty Stabilization Leg															
Part No.	Mech. Locking	Bore		Stroke (SL)		Mounting Height (MH)		Bracket Width (W)		Bracket Height		Hole Width		Weight	
		in.	mm	in.	mm	in.	mm	in.	mm	in.	mm	in.	mm	lbs.	kg
9010001341	Yes	5.0	127	12.0	305	18.65	473.7	12.0	305	11.0	279	10.0	254	240	108.86
9010001347	Yes	5.0	127	18.0	457	34.65	880.1	12.0	305	25.5	648	10.0	254	320	145.15
9010001345	Yes	5.0	127	24.0	610	34.65	880.1	12.0	305	25.5	648	10.0	254	375	170.10
9010001346	Yes	5.0	127	36.0	914	34.65	880.1	12.0	305	25.5	648	10.0	254	420	190.51
9010001290	Yes	6.0	152	12.0	305	18.65	473.7	12.0	305	11.0	279	10.0	254	280	127.01
9010001292	Yes	6.0	152	18.0	457	34.65	880.1	12.0	305	25.5	648	10.0	254	370	167.83
9010001293	Yes	6.0	152	24.0	610	34.65	880.1	12.0	305	25.5	648	10.0	254	430	195.04
9010001294	Yes	6.0	152	36.0	914	34.65	880.1	12.0	305	25.5	648	10.0	254	480	217.72

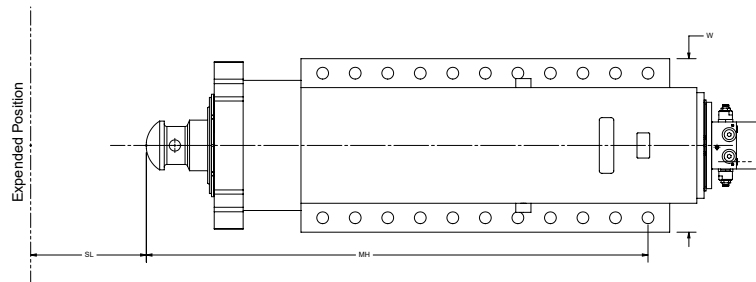

# HYDRAULIC CYLINDERS



## Simple, durable and safe delivery of power

Whether you need to push, pull, lift or lower your equipment, our hydraulic cylinders deliver controlled, reliable, safe actuation of your equipment. Offered in a variety of different strokes, bores and mounting configurations, our hydraulic cylinders' tube-in-tube design helps you minimize damage.

### HYDRAULIC CYLINDERS OVERVIEW FOR UP TO 5,000 PSI OPERATING PRESSURE

#### FLEXIBILITY

A variety of stroke, bore and mounting configurations are available. A fixed return tube means the retract and extend ports can be in the same location for easier hose routing and installation.

#### RELIABILITY

Our cylinders are designed for a high duty cycle and constructed to deliver maximum performance for the most rigorous applications. An optional filter is available on select models to keep out contaminants.

#### SINGLE- OR DOUBLE-ACTING DESIGNS

Single-acting cylinders are cost effective for simple applications. Double-acting cylinders provide precise control and offer controlled movement in from either end of the cylinder.



## HYDRAULIC CYLINDERS

Available in single- or double-acting designs, our reliable, lightweight cylinders offer a variety of rod-end and base-mounting configurations. Optional tamper-proof velocity fuses and built-in flow control features are also available. Other important features and benefits include:

- 6- to 23-inch standard stroke lengths
- 3,500-5,000 psi maximum operating pressure
- 1.5- to 2.5-inch bore diameters
- Fixed return tube
- Available with pilot-operated check valves or dual, counterbalance valves

## Why Choose Power-Packer Hydraulic Cylinders

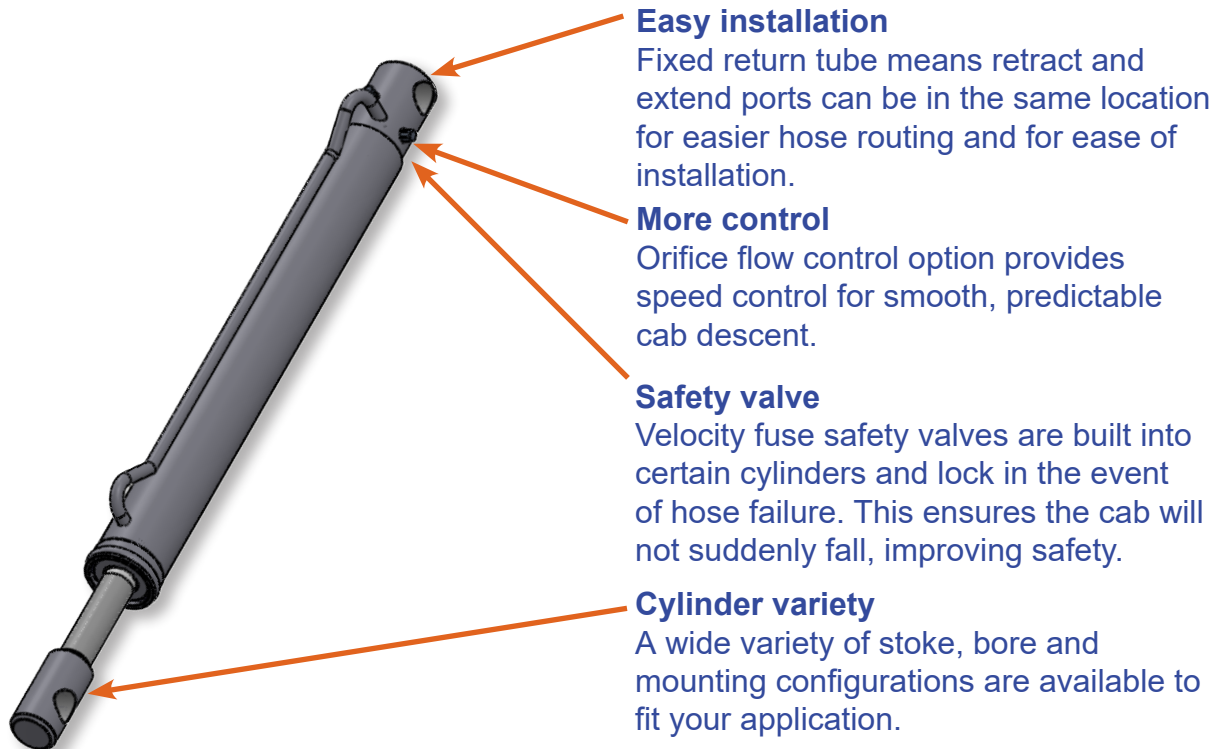

# HYDRAULIC CYLINDERS

Hydraulic Cylinders															
Part No.	Bore		Stroke (SL)		Retracted Length		Extended Length		Ports	Single/Double Acting	Velocity Fuse	Max Working Pressure		Weight	
	in.	mm	in.	mm	in.	mm	in.	mm				psi	bar	lbs.	kg
CB15061200	1.5	38	5.63	143	10.68	271	16.25	413	1/8-27 NPTF	S	Yes	500	34.47	4.0	1.81
9010001164	1.5	38	6.23	158	17.00	432	23.23	590	1/8-27 NPTF	S	Yes	5000	344.74	6.0	2.72
CA15067300	1.5	38	6.23	158	17.00	432	23.23	590	1/8-27 NPTF	D	Yes	5000	344.74	6.5	2.95
CA15087501	1.5	38	7.88	200	13.50	343	21.38	543	1/8-27 NPTF	D	Yes	5000	344.74	6.0	2.72
CA15097302	1.5	38	8.37	213	17.00	432	25.37	644	1/8-27 NPTF	D	Yes	5000	344.74	10.0	4.54
CA15099301	1.5	38	8.50	216	8.84	225	17.31	440	1/8-27 NPTF	D	Yes	3500	241.32	7.0	3.18
CS10127502	1.5	38	12.00	305	18.25	464	30.25	768	1/4-18 NPTF	S	Yes	5000	344.74	7.0	3.18
9010001335	1.5	38	13.00	330	19.50	495	32.50	826	1/8-27 NPTF	S	No	5000	344.74	8.5	3.86
CS10137302	1.5	38	13.00	330	19.50	495	32.50	826	1/8-27 NPTF	S	No	5000	344.74	7.0	3.18
DCD2-100416	1.5	38	13.00	330	18.30	465	31.30	795	M14x515	D	No	5000	344.74	9.0	4.08
CA15137310	1.5	38	13.12	333	18.75	476	31.87	809	1/8-27 NPTF	D	Yes	5000	344.74	7.0	3.18
CA15137311	1.5	38	13.12	333	18.75	476	31.87	809	1/8-27 NPTF	D	Yes	5000	344.74	7.0	3.18
CA15137317	1.5	38	13.12	333	18.75	476	31.87	809	1/8-27 NPTF	D	Yes	5000	344.74	7.0	3.18
CD15157502	1.5	38	15.16	385	24.37	619	38.66	982	1/8-27 NPTF	D	No	5000	344.74	6.0	2.72
CD15157504	1.5	38	15.16	385	24.33	618	38.75	984	1/8-27 NPTF	D	No	5000	344.74	6.0	2.72
CA15167316	1.5	38	16.20	411	21.35	542	37.55	954	1/8-27 NPTF	D	Yes	5000	344.74	7.0	3.18
CA15167317	1.5	38	16.20	411	21.35	542	37.55	954	1/8-27 NPTF	D	Yes	5000	344.74	7.0	3.18
CA15167310	1.5	38	16.25	413	23.50	597	39.75	1010	1/8-27 NPTF	D	Yes	5000	344.74	7.0	3.18
CA15167313	1.5	38	16.25	413	23.50	597	39.75	1010	1/8-27 NPTF	D	Yes	5000	344.74	7.0	3.18
CA15167315	1.5	38	16.25	413	23.50	597	39.75	1010	1/8-27 NPTF	D	Yes	5000	344.74	7.0	3.18
CA15187503	1.5	38	17.67	449	28.45	723	46.12	1171	1/8-27 NPTF	D	Yes	5000	344.74	8.0	3.63
CA15187501	1.5	38	17.82	453	25.94	659	43.75	1111	1/8-27 NPTF	D	Yes	5000	344.74	7.0	3.18
CA15187506	1.5	38	18.07	459	28.45	723	46.52	1182	SAE#4	D	Yes	5000	344.74	8.0	3.63
CA15227504	1.5	38	21.81	554	29.62	752	51.43	1306	1/8-27 NPTF	D	Yes	5000	344.74	12.0	5.44
CS10237502	1.5	38	23.00	584	29.25	743	52.25	1327	1/4-18 NPTF	S	No	5000	344.74	12.0	5.44
CA15307500	1.5	38	30.16	766	44.20	1123	74.36	1889	1/8-27 NPTF	D	Yes	5000	344.74	18.0	8.16
9010001166	1.625	41	29.00	737	38.00	965	67.00	1702	SAE#6	D	No	3500	241.32	25.0	11.34
9010001286	1.625	41	29.00	737	37.50	953	66.50	1689	SAE#4	D	No	3500	241.32	27.0	12.25



# HYDRAULIC CYLINDERS

Hydraulic Cylinders															
Part No.	Bore		Stroke (SL)		Retracted Length		Extended Length		Ports	Single/Double Acting	Velocity Fuse	Max Working Pressure		Weight	
	in.	mm	in.	mm	in.	mm	in.	mm				psi	bar	lbs.	kg
CD20053300-TAN	2	51	4.50	114	11.90	302	16.40	417	SAE#4	S	No	4000	275.79	14.0	6.35
CD20053301	2	51	6.00	152	12.38	314	18.38	467	SAE#4	S	No	3500	241.32	14.0	6.35
CA20107307	2	51	10.38	264	17.88	454	28.26	718	1/8-27 NPTF	D	Yes	5000	344.74	6.0	2.72
DCD171117694	2	51	11.30	287	22.40	569	33.70	856	M12x15	D	No	6000	413.69	17.0	7.71
9010001340	2	51	12.90	328	26.00	660	38.90	988	SAE#4	D	No	3500	241.32	15.0	6.80
CA20157305	2	51	13.12	333	26.00	660	32.87	835	SAE#4	D	Yes	3500	241.32	17.0	7.71
9010000178	2	51	15.75	400	26.25	667	42.00	1067	SAE#4	D	Yes	4350	299.92	18.0	8.16
9010001221-TAN	2	51	15.75	400	26.25	667	42.00	1067	SAE#4	D	No	4350	299.92	12.0	5.44
CA20157303	2	51	15.75	400	26.25	667	42.00	1067	SAE#4	D	Yes	3500	241.32	8.0	3.63
CA20157304	2	51	15.75	400	26.00	660	41.75	1060	SAE#4	D	Yes	3500	241.32	10.0	4.54
CA20167304	2	51	15.94	405	26.00	660	41.94	1065	SAE#4	D	Yes	3500	241.32	12.0	5.44
9010000470	2	51	16.38	416	34.00	864	50.38	1280	SAE#4	D	No	3500	241.32	20.0	9.07
CA20187304	2	51	17.65	448	28.45	723	46.10	1171	1/8-27 NPTF	D	Yes	3500	241.32	14.0	6.35
CA20187307	2	51	18.07	459	28.45	723	46.52	1182	SAE#4	D	Yes	3500	241.32	15.0	6.80
CA20197300	2	51	18.75	476	25.17	639	43.92	1116	1/8-27 NPTF	D	Yes	3000	206.84	15.0	6.80
CA20197301	2	51	18.75	476	25.17	639	43.92	1116	1/8-27 NPTF	D	Yes	3500	241.32	15.0	6.80
9010000321	2	51	23.00	584	34.00	864	57.00	1448	SAE#4	D	No	3500	241.32	30.0	13.61
CD23073501	2.25	57	7.25	184	13.60	345	20.85	530	SAE#6	S	No	5000	344.74	16.0	7.26
CD23113500-TAN	2.25	57	10.75	273	17.10	434	27.85	707	SAE#6	S	No	5000	344.74	16.0	7.26
9010000217-TAN	2.5	64	12.39	315	19.00	483	31.39	797	SAE#4	D	No	5000	344.74	20.0	9.07
CD25149500	2.5	64	13.63	346	26.63	676	40.25	1022	SAE#4	D	Yes	4500	310.26	20.0	9.07

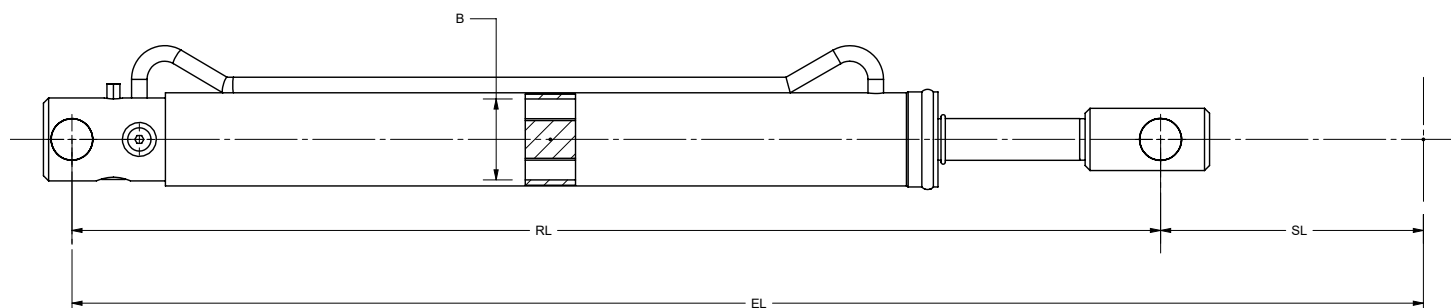

# HYDRAULIC LATCHES



## Safe, secure connection between two joints of a system

Our latches provide a safe, secure way to ensure covers and cabs are locked down for travel. Designed to be compact and versatile while still delivering the strength you need, our uniquely designed hydraulic latches clearly indicate when the latch is engaged.

### HYDRAULIC LATCH OVERVIEW FOR UP TO 10,000 LB. VERTICAL LOAD

#### SECURE CONNECTION

Safely and securely create a connection between two joints of a system during operation.

#### VERSATILITY

The compact latch size delivers on strength, single or multiple uses, and fits into limited footprint space locations in your design.

#### DESIGNED FOR EASY SAFETY DETECTION

The unique design includes a latch indicator that shows when the latch is engaged.



## HYDRAULIC LATCHES

Our unique, compact, user-friendly design has a visual latch indicator or an indicator switch that can be integrated into the vehicle safety system with a light or a vehicle interlock. The latch locks mechanically and releases hydraulically. Other features and benefits include:

- **Maximum vertical pull load of 10,000 pounds**
- **Maximum hydraulic pressure of 5,000 psi**
- **-30 to 130 F operating temperature**
- **Corrosion resistance of 200 hours per ANSI B1117**
- **Fluid: MIL-PRF-5606 or equivalent**
- **Design includes one of these latch indicators:**
  - **Visual indicator**
  - **Electrical positional indicator switch**

## Why Choose Power-Packer Hydraulic Latches

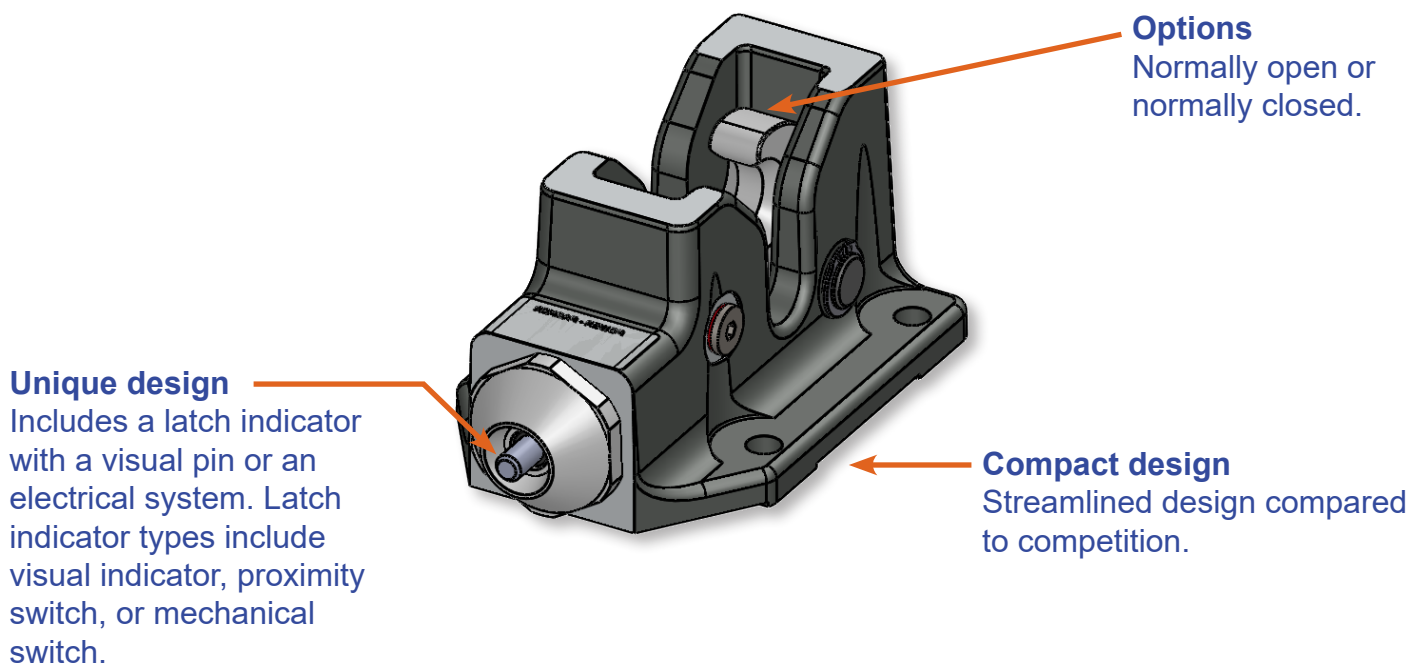

# HYDRAULIC LATCHES

Hydraulic Latches													
Part No.	Description	Height		Length		Top Length		Mounting Holes	Base Dimensions		Indicator Type	Weight	
		in.	mm	in.	mm	in.	mm		in.	mm		lbs.	g
LH30037213	CAB LATCH	9.00	228.6	6.25	158.8	N/A	N/A	2	6.25X3.5	158.8X88.9	None	9.7	4399.84
LH30037220	CAB LATCH	9.00	228.6	5.50	139.7	N/A	N/A	4	5.5X4	139.7X101.6	None	10.2	4608.49
LH30037221	CAB LATCH	10.80	274.3	5.50	139.7	N/A	N/A	4	5.5X4	139.7X101.6	None	12.8	5805.98
LH30037230	CAB LATCH	9.60	243.8	5.50	139.7	N/A	N/A	5	5.5X4	139.7X101.6	None	12.8	5805.98
LH30037232	CAB LATCH	9.00	228.6	6.25	158.8	N/A	N/A	2	6.25X3.5	158.8X88.9	None	9.7	4399.84
LH30037233	CAB LATCH	9.00	228.6	6.25	158.8	N/A	N/A	2	6.25X3.5	158.8X88.9	None	9.7	4399.84
LH30037235	CAB LATCH	9.65	245.1	5.38	136.7	N/A	N/A	4	5.38X4	136.7X101.6	None	11.8	5352.39
LH30037236	CAB LATCH	10.15	257.8	5.38	136.7	N/A	N/A	4	5.38X4	136.7X101.6	None	12.7	5760.62
LH50000101	LATCH ASM VISUAL INDICATOR W/ SWITCH	3.75	95.3	6.60	167.6	4.5	114.3	4	4.5X4	114.3X101.6	VISUAL INDICATOR	3.4	1542.21
LH50000102	LATCH ASM VISUAL INDICATOR OPEN FREIGHT-LINER	3.20	81.3	6.60	167.6	4.5	114.3	4	4.5X4	114.3X101.6	VISUAL INDICATOR	3.6	1623.86
LH50000104	LATCH	3.20	81.3	6.60	167.6	4.5	114.3	4	4.5X4	114.3X101.6	VISUAL INDICATOR	3.4	1542.21
LH50000105	LATCH ASM WITH GREEN PAINT	3.20	81.3	6.50	165.1	4.5	114.3	4	4.5X4	114.3X101.6	VISUAL INDICATOR	3.6	1637.47
LH50000107	LATCH ASM VISUAL INDICATOR W/ SWITCH	3.20	81.3	6.50	165.1	4.5	114.3	4	4.5X4	114.3X101.6	NORMALLY ON	3.4	1542.21
LH50000108	LATCH ASM VISUAL INDICATOR W/ CATCH	3.50	88.9	6.50	165.1	4.5	114.3	4	4.5X4	114.3X101.6	VISUAL INDICATOR	3.4	1542.21
LH50000109	LATCH, PACKARD CONNECTOR	3.20	81.3	6.50	165.1	4.5	114.3	4	4.5X4	114.3X101.6	NORMALLY ON PACKARD CONNECTOR	3.4	1542.21
LH50000111	LATCH ASM VISUAL INDICATOR W/CATCH & FITTINGS	3.20	81.3	6.50	165.1	4.5	114.3	4	4.5X4	114.3X101.6	VISUAL INDICATOR	3.4	1542.21
LH50000112	LATCH ASM VISUAL INDICATOR AND BRACKET	3.53	89.7	6.50	165.1	4.5	114.3	4	4.5X4	114.3X101.6	VISUAL INDICATOR	4.1	1841.58
LH50000114	LATCH NORMALLY ON	3.20	81.3	6.50	165.1	4.5	114.3	4	4.5X4	114.3X101.6	VISUAL INDICATOR	3.4	1542.21

# HYDRAULIC LATCHES

Hydraulic Latches													
Part No.	Description	Height		Length		Top Length		Mounting Holes	Base Dimensions		Indicator Type	Weight	
		in.	mm	in.	mm	in.	mm		in.	mm		lbs.	g
LH50000116	LATCH, PACKARD CONNECTOR	3.20	81.3	6.50	165.1	4.5	114.3	4	4.5X4	114.3X101.6	NORMALLY ON PACKARD CONNECTOR	3.4	1542.21
LH50000118	LATCH	3.20	81.3	6.50	165.1	4.5	114.3	4	4.5X4	114.3X101.6	NORMALLY CLOSED	3.4	1542.21
LH50000119	LATCH ASM VISUAL INDICATOR	3.20	81.3	6.50	165.1	4.5	114.3	4	4.5X4	114.3X101.6	NORMALLY OPEN	3.4	1542.21
LH50000123	LATCH NORMALLY CLOSED W/PROXIMITY SENSOR	3.20	81.3	6.50	165.1	4.5	114.3	4	4.5X4	114.3X101.6	NORMALLY CLOSED	3.4	1542.21
LH50000124	LATCH ASM AND SWP CONNECTOR	3.20	81.3	6.50	165.1	4.5	114.3	4	4.5X4	114.3X101.6	NORMALLY OPEN	3.6	1642.00
LH50000125	LATCH ASM, SWP CONNECTOR, AND BLEEDER	3.20	81.3	6.50	165.1	4.5	114.3	4	4.5X4	114.3X101.6	NORMALLY OPEN	3.7	1660.15
LH50000126	LATCH ASM W/PROX SWITCH	3.20	81.3	6.50	165.1	4.5	114.3	4	4.5X4	114.3X101.6	NORMALLY OPEN	3.7	1691.90
LH50000127	LATCH ASM VISUAL INDICATOR W/ SWITCH	3.20	81.3	6.50	165.1	4.5	114.3	4	4.5X4	114.3X101.6	VISUAL INDICATOR	3.4	1542.21
LH50000129	LATCH ASM W/TRUCK SWITCH	3.20	81.3	6.50	165.1	4.5	114.3	4	4.5X4	114.3X101.6	NORMALLY CLOSED	4.0	1814.37
LH50000132	LATCH ASM HYD	3.20	81.3	6.50	165.1	4.5	114.3	4	4.5X4	114.3X101.6	VISUAL INDICATOR	3.4	1542.21

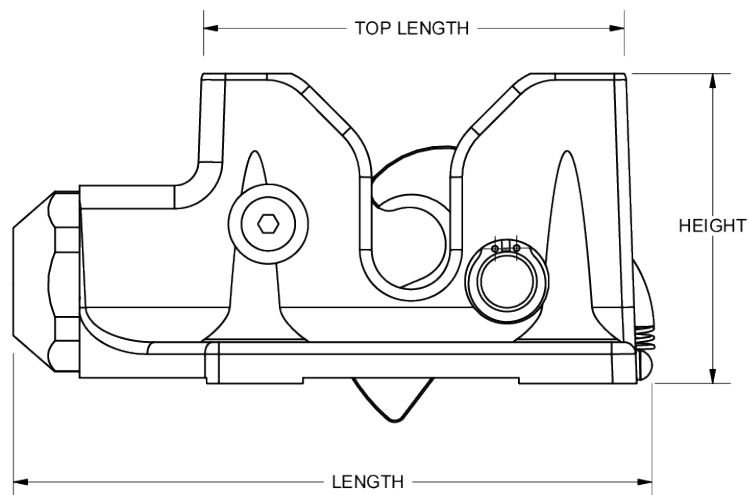

# CAB SUSPENSION



## A smoother ride with improved durability

Ride quality matters. When a truck rides better, the driver is happier, healthier and more productive. Cab suspension components are crucial to enhancing driver comfort and reducing fatigue due to long hours behind the wheel. Learn how Power-Packer's cab suspension system enhances driver safety and comfort.

### CAB SUSPENSION OVERVIEW FOR UP TO 2,000 LB VERTICAL LOAD

#### SAFETY & COMFORT

Isolate the driver and cab from vibration damage and shock, improving driver safety and comfort, while decreasing cab wear and tear. Cab suspension is adjustable and available for driver and passenger sides of the vehicle.

#### INTEGRATION OPTIONS

Integrate latches with suspension assemblies for one complete system.

#### DESIGN OPTIONS

Cab suspension is available with and without rubber dampers. Rubber dampers are ideal for rough duty cycles, because the arm limits air shock travel, increasing the life cycle in rougher terrain.



## CAB SUSPENSION

A bolt-on air cab suspension system that is easily integrated into your next application. With the option to place on either the driver or passenger side, our cab suspension creates a smooth ride for passengers, while eliminating the wear and tear on your vehicle. Other features and benefits include:

- 120 psi max operating pressure
- 2,000 lb. load capacity at 100 psi
- 1.7 in. vertical suspension travel

## Why Choose Power-Packer Cab Suspension

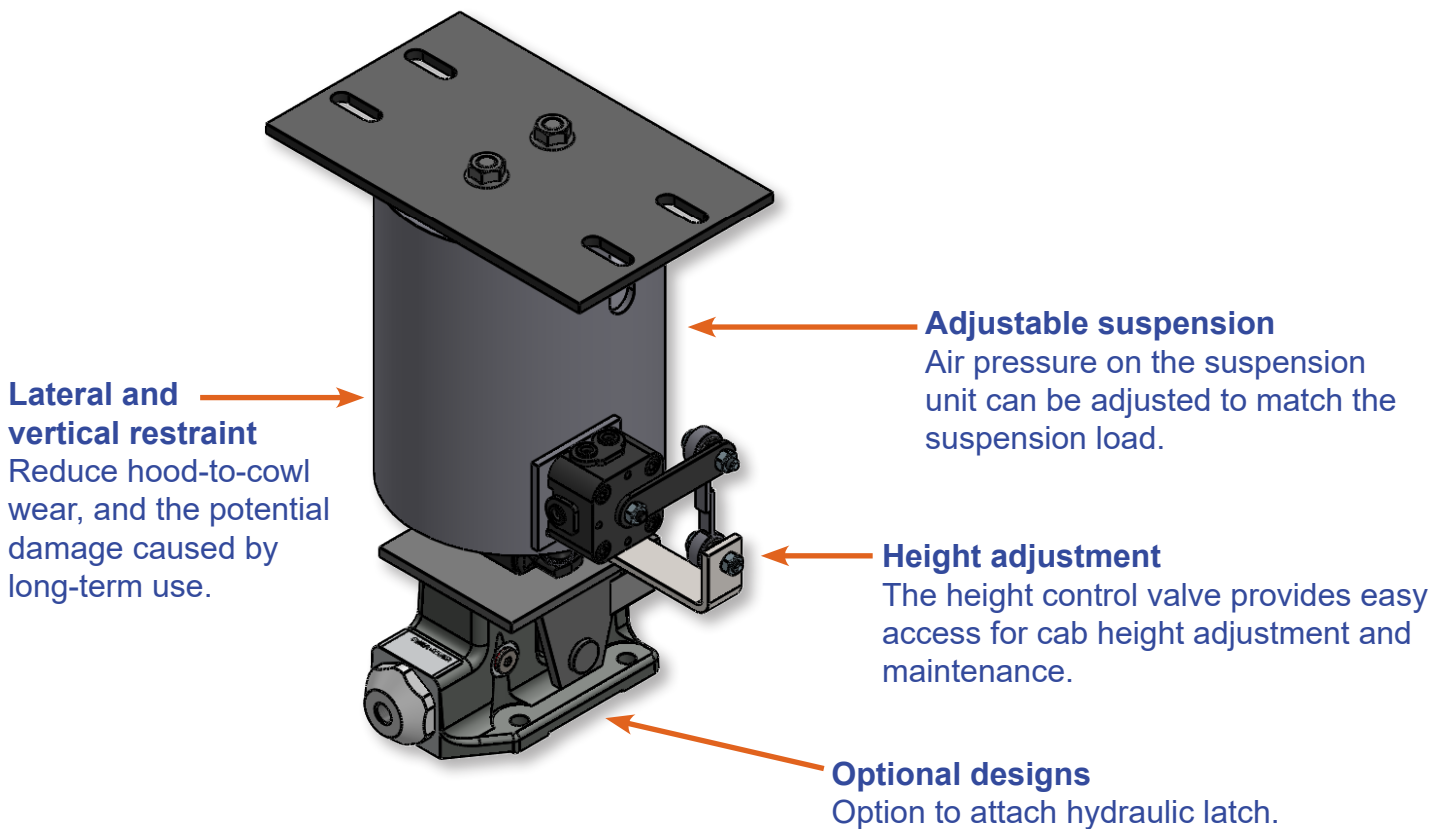

# CAB SUSPENSION

Cab Suspension										
Part No.	Height		Mounting Width		Mounting Length		Max Operating Pressure		Load Capacity at 100 psi (kN) at 6.9 bar	
	in.	mm	in.	mm	in.	mm	psi	bar	lbs.	kg
<b>Driver</b>										
AS50101331	11.7	297.2	2.25	57.2	6.7-8.5	170.2-215.9	120	8.27	2000	907.18
KA5089	11.7	297.2	2.25	57.2	6.7-8.5	170.2-215.9	120	8.27	2000	907.18
AS50101335	11.7	297.2	2.25	57.2	6.7-8.5	170.2-215.9	120	8.27	2000	907.18
AS50101319	11.7	297.2	2.25	57.2	6.7-8.5	170.2-215.9	120	8.27	2000	907.18
PP938900-2G	11.7	297.2	2.25	57.2	6.7-8.5	170.2-215.9	120	8.27	2000	907.18
<b>Passenger</b>										
AS50101332	11.7	297.2	2.25	57.2	5.3-6.9	134.6-175.3	120	8.27	2000	907.18
KA5090	11.7	297.2	2.25	57.2	5.3-6.9	134.6-175.3	120	8.27	2000	907.18
AS50101336	11.7	297.2	2.25	57.2	5.3-6.9	134.6-175.3	120	8.27	2000	907.18
AS50101320	11.7	297.2	2.25	57.2	5.3-6.9	134.6-175.3	120	8.27	2000	907.18
PP939900-2G	11.7	297.2	2.25	57.2	5.3-6.9	134.6-175.3	120	8.27	2000	907.18
KA5083	11.7	297.2	2.25	57.2	6.7-8.5	170.2-215.9	120	8.27	2000	907.18
KA5084	11.7	297.2	2.25	57.2	6.7-8.5	170.2-215.9	120	8.27	2000	907.18
KA5087	11.7	297.2	2.25	57.2	6.7-8.5	170.2-215.9	120	8.27	2000	907.18
KA5088	11.7	297.2	2.25	57.2	6.7-8.5	170.2-215.9	120	8.27	2000	907.18

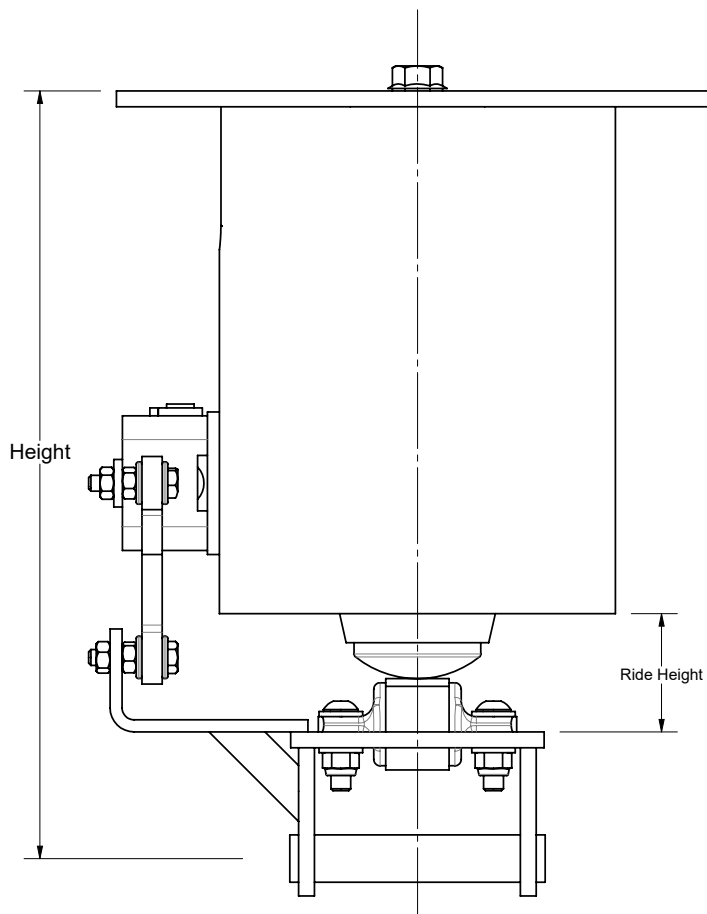



# HYDRAULIC PUMPS



## Deliver the right amount of energy to get your equipment moving

Choose from a variety of hydraulic pump designs to meet your specific energy transfer needs.

### HYDRAULIC PUMPS OVERVIEW FOR UP TO MAXIMUM OF 5,000 PSI

#### BUILD A SYSTEM

Choose a pump as part of a built system (pump, cylinder and latch), and you can consolidate vendors and potentially reduce production lead times. Plus, each of our products is engineered to seamlessly integrate into your hydraulic circuit for peak efficiency.

#### FLEXIBILITY

Power-Packer offers a variety of pump sizes and designs (hand, air or electric) to meet your specific needs, from high-quality electric pumps that simply require the push of a button, to standard hand pumps that ensure work doesn't stop even if you lose power.

#### STREAMLINED FLOW CONTROL

Each pump has an integrated, directional control valve that allows the operator to easily raise and lower the cab. The spool has a built-in metering orifice to control the flow as the cab descends.



## HYDRAULIC PUMPS

Whether you need a basic hydraulic hand pump, or are looking for a more advanced pump that activates at the touch of a button, Power-Packer has a variety of hydraulic pumps that will easily integrate into your application.

Hand pumps	Air and electric pumps	All pumps
Relief valve setting: 1,800-5,500 psi (124 to 380 bar)	Relief valve setting: 3,200 to 3,500 psi (220.7 to 241.4 bar)	Recommended operating temperature: -30 to 130 F (-34 to 54 C)
Maximum operating pressure: 5,500 psi (380 bar)	Maximum operating pressure: 3,500 psi (269 bar)	Reservoir capacity: 35 and 70 cubic in. (574 and 1,178 cubic cm)
Weight: 5.3 lbs. (2.4 kg)	Weight: 7.8 lbs. (3.5 kg)	Fluid: MIL-PRF-5606 or equivalent. Do not use ATF.

## Why Choose Power-Packer Hydraulic Pumps

### Vented fill plug

All pumps come with an SAE-certified fill plug that doubles as an air vent to protect the system from external contamination.

### Operation pressure

Pumps deliver operating pressure that ranges from 1,800 to 5,500 psi.

### Back-up hand pump

Our electric and air pumps come with a manual back-up hand pump to ensure a cab remains operational. This should be used when electric or air power is not available.

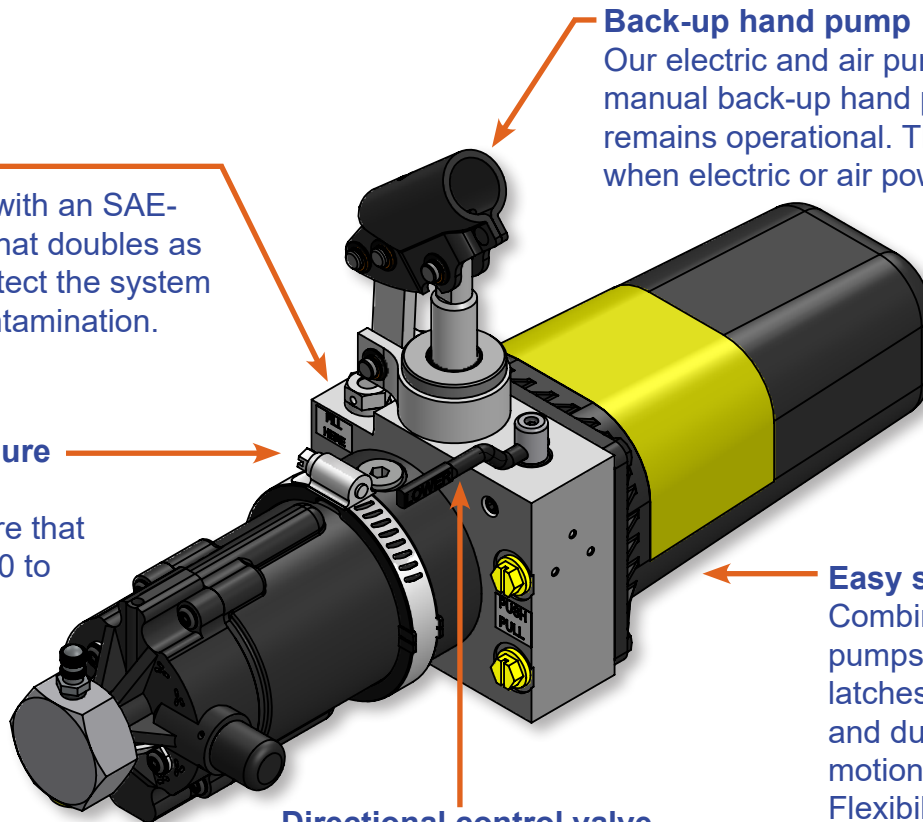

### Directional control valve

Lever-operated rotary directional valve.

### Easy system integration

Combining our hydraulic pumps, cylinders and latches creates a powerful and durable hydraulic motion control system. Flexibility allows you to choose hand, air or electric pumps.

# HYDRAULIC PUMPS

Hydraulic Pumps					
Part No.	Pressure Relief Setting		Description	Working Volume	
	psi	bar		Cubic in.	Liter
9010001310	3200-3500	220.6-241.3	AIR PUMP (.69) 3200 35CI	35	0.574
AU1340413	4000-4300	275.8-296.5	UNIT AIR/MANUAL PUMP	35	0.574
AU1340414	4000-4300	275.8-296.5	AIR/MANUAL PUMP	65	1.065
AU1340415	1700-2000	117.2-137.9	AIR/MANUAL PUMP	35	0.574
AU1340417	3200-3500	220.6-241.3	AIR/MANUAL PUMP	35	0.574
AU1340418	3200-3500	220.6-241.3	AIR PUMP	35	0.574
AU1340419	2700-3000	186.2-206.8	AIR/MANUAL PUMP	35	0.574
AU1340420	2700-3000	186.2-206.8	AIR/MANUAL PUMP	65	1.065
AU1340421	3200-3500	220.6-241.3	AIR PUMP	65	1.065
AU1340423	3200-3500	220.6-241.3	PUMP ASSY AIR / MANUAL .75	65	1.065
AU1340424	2700-3000	186.2-206.8	AIR/MANUAL PUMP	65	1.065
AU1340426	3700-4000	255.1-275.8	AIR/MANUAL PUMP 3700-4000 NO DECAL SHORT HANDLE	65	1.065
AU1540413	4500-4800	310.3-331.0	ASSEMBLY AIR/MANUAL PUMP	35	0.574
AU1540417	3800-4200	262.0-289.6	ASSEMBLY AIR PUMP	35	0.574
AU1540418	4000-4200	275.8-289.6	AIR PUMP (.56) 4000 35CI	35	0.574
AU1540420	4000-4200	275.8-289.6	ASSEMBLY AIR PUMP (LONG)	65	1.065
AU1540422	4000-4200	275.8-289.6	MANUAL ASSY AIR PUMP	65	1.065
AU1540424	3800-4200	262.0-289.6	ASSEMBLY AIR PUMP	35	0.574
AU1540425	3800-4200	262.0-289.6	AIR/MANUAL PUMP .56 3800-4200	35	0.574
EP25044300	2100-2400	144.8-165.5	PUMP CAB TILT ELECTRIC/MANUAL 24V .69 2400 DEUTSCH	60	0.983
EP35013300	3100-3400	213.7-234.4	PUMP CAB TILT ELECTRIC/MANUAL 12V .69 3400	60	0.983
EP35013301	2700-3000	186.2-206.8	PUMP CAB TILT ELECTRIC/MANUAL 12V .69 3000	60	0.983
EP35013304	3100-3400	213.7-234.4	PUMP CAB TILT ELECTRIC/MANUAL 24V .69 3400 METRI-PACK	60	0.983
EP35013308	3100-3400	213.7-234.4	PUMP CAB TILT ELECTRIC/MANUAL 24V .69 3400 DEUTSCH	60	0.983
EP35013311	3100-3400	213.7-234.4	PUMP CAB TILT ELECTRIC/MANUAL 12V .69 3400	35	0.574
HP50024204	4000-4200	275.8-289.6	HAND PUMP (.56) 4000 35CI PAINTED FMTV CAB TILT	35	0.574

# HYDRAULIC PUMPS

Hydraulic Pumps					
Part No.	Pressure Relief Setting		Description	Working Volume	
	psi	bar		Cubic in.	Liter
HP50024207	5200-5500	358.8-379.2	HAND PUMP .56	35	0.574
HP50024209	6000-6200	413.7-427.5	HAND PUMP (.56) 6000 35CI SPINDLE	35	0.574
HP50027203	4700-5000	324.1-344.7	HAND PUMP (.56) 4700 65CI SPINDLE	65	1.065
HP50034200	4700-5000	324.1-344.7	HAND PUMP (.69) 4000 35CI LEVER	35	0.574
HP50034201	4000-4300	275.8-296.5	HAND PUMP (.69)	35	0.574
HP50034203	3200-3500	220.6-241.3	PUMP, HAND	35	0.574
HP50034204	4000-4300	275.8-296.5	HAND PUMP (.69) 4000 35CI LEVER	35	0.574
HP50034206	3200-3500	220.6-241.3	HAND PUMP (.69) 3200 35CI LEVER	35	0.574
HP50034207	3600-3900	248.2-268.9	HAND PUMP (.69) 3600 35CI LEVER	35	0.574
HP50034208	2700-3200	186.2-220.6	HAND PUMP (.69) 2700 35CI W ADAPTER SERVICE	35	0.574
HP50034210	4000-4300	275.8-296.5	HAND PUMP (.69) 4000 35CI LEVER	35	0.574
HP50034216	3600-3900	248.2-268.9	HAND PUMP (.69) 3600 35CI PADDLE	35	0.574
HP50037200	2700-3000	186.2-206.8	HAND PUMP (.69) 4000 65CI LEVER	35	0.574
HP50037202	2700-3000	186.2-206.8	HAND PUMP (.69)W/ADAPTER +SERV	35	0.574
HP50037203	2700-3000	186.2-206.8	HAND PUMP (.69) 2700 65CI LEVER	35	0.574
HP50037205	4000-4300	275.8-296.5	HAND PUMP (.69)	35	0.574
HP50037207	3200-3500	220.6-241.3	UNIT HAND PUMP LARGE RESERVO	35	0.574
HP50044201	3200-3500	220.6-241.3	HAND PUMP (.75) 3200 35CI LEVER	35	0.574
HP50044203	2100-2300	144.8-158.6	HAND PUMP (.75)	35	0.574
HP50044204	3200-3500	220.6-241.3	HAND PUMP (.75) 3200 35CI LEVER	35	0.574
HP50044207	3200-3500	220.6-241.3	HAND PUMP (.75)	35	0.574
HP50044208	3000-3200	206.8-220.6	HAND PUMP (.75) 3000 35CI SPINDLE W HANDLE	35	0.574
HP50044210P	3200-3500	220.6-241.3	ASM HYD HAND PUMP W/ PACKI	35	0.574
HP50044215	3200-3500	220.6-241.3	HAND PUMP (.75) 3200 35 CI W/ DUAL PORT BODY	35	0.574
HP50047201	3000-3200	206.8-220.6	HAND PUMP (.75)	35	0.574

# VALVE ASSEMBLIES & CONTROL BOXES



## Power, performance and reliability for the toughest applications

Maintain complete operation over your hydraulic systems with control boxes that feature a self-contained power source.

### VALVE ASSEMBLIES & CONTROL BOXES

#### LOAD HOLDING

Valve assemblies' loads are held by the load valves at the leg not at the control valve. Additionally, the hoses are only pressurized when the leg is in motion.

#### VALVE OPTIONS

Valve options include spool valve control, up to six cylinders, with either manual operation or solenoid spool operation. Integral relief in the spool valve protects the system from excessive pump pressure. The relief is set at 2,500 psi for standard units.

#### RESERVOIR OPTIONS

Sizes available from 6.5 to 13 gallons. Ten-micron filtration, reservoir breather and an oil level gauge are included in the reservoir assembly.

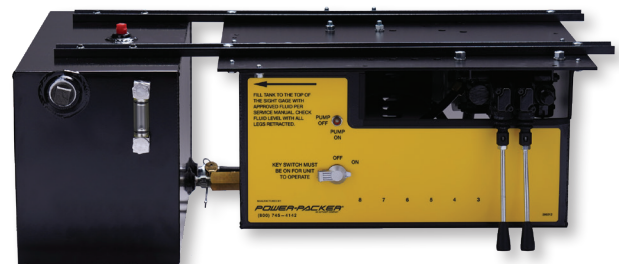

## VALVE ASSEMBLIES & CONTROL BOXES

Available in a variety of configurations, Power-Packer's control boxes are designed to meet your unique application needs. Features include:

- **Electric- or gas-powered hydraulic controls**
- **2- to 6-valve manual or pendant flow control**
- **6.5- or 11-gallon reservoir options**

## Why Choose Power-Packer Valve Assemblies & Control Boxes

### VALVE ASSEMBLY

#### **Stability**

Control is better maintained because the load is held by the valves at the leg, not at the control valve. Torque output can also be precisely adjusted.

#### **Smooth retraction operation**

Helps maintain smooth movement when operating the cylinder, stabilization legs or outriggers.

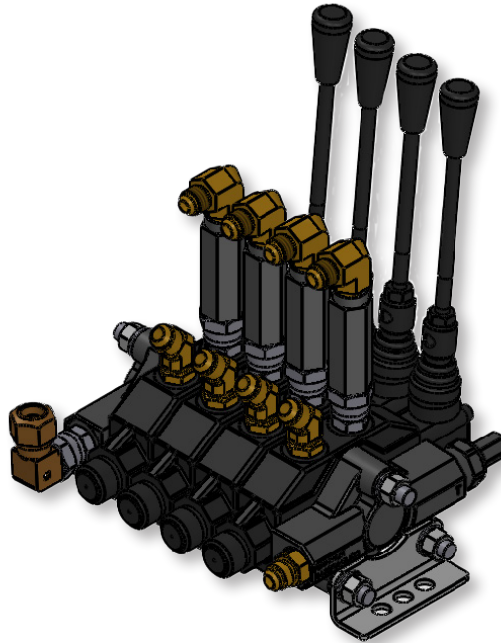

### CONTROL BOX

Standard control boxes use manually operated directional control valves for independent control of up to six legs.

Electrical control option has a handheld pendant for remote operation of the control box valve spools, with a 20-foot cable on the pendant for ease of operation.

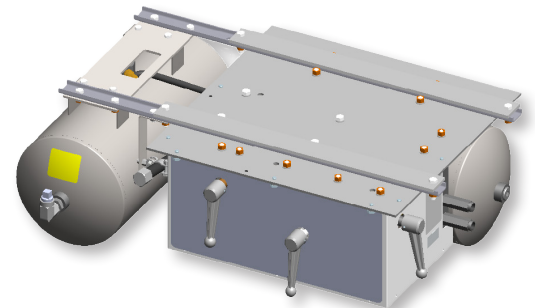

## VALVE ASSEMBLIES & CONTROL BOXES

Valve Assemblies		
Part No.	Number of Valves	Notes
3025-2	2	VALVE 2 BANK 2 OC PO ASSY
3025-4	4	VALVE 4 BANK 4 OC PO ASSY
3025-5	5	VALVE 5 BANK 5 OC PO ASSY
3025-6	6	VALVE 6 BANK 6 OC PO ASSY
3027-4	4	VALVE 4 BANK 4 OC PB ASSY

Control Boxes										
Part No.	Input Power	# of Valves	Valve Type	Valve Configuration	Reservoir Size		Flow Rate		Power Beyond	Pendant Control
					Gallon	Liter	gpm	lpm		
300546-ES	12 V DC	0			11.0	41.64	1.3	4.92	No	No
300215-ES	12 V DC	2	Manual	OPEN CTR	6.5	24.61	1.3	4.92	No	No
300217	12 V DC	4	Manual	OPEN CTR	6.5	24.61	1.3	4.92	No	No
300400-ES	12 V DC	4	Manual	OPEN CTR	6.5	24.61	1.3	4.92	Yes	No
3510000227	12 V DC	4	Solenoid	OPEN CTR	6.5	24.61	1.3	4.92	No	Pendant
300223	12 V DC	5	Manual	OPEN CTR	6.5	24.61	1.3	4.92	No	No
300219-ES	12 V DC	6	Manual	OPEN CTR	6.5	24.61	1.3	4.92	No	No
300231-ES	12 V DC	6	Manual	OPEN CTR	6.5	24.61	1.3	4.92	Yes	No
300251-ES	24 V DC	2	Manual	OPEN CTR	6.5	24.61	1.8	6.81	No	No
300253-ES	24 V DC	4	Manual	OPEN CTR	6.5	24.61	1.8	6.81	No	No
3510000356	24V DC	4	Manual	OPEN CTR	6.5	24.61	1.8	6.81	No	No
3510000402	575 V AC	4	Solenoid	OPEN CTR	6.5	24.61	2.1	7.95	No	Pendant
300600	Gas Powered	0			11.0	41.64	2.8	10.41	No	No

# HYDRAULIC STABILIZATION, POSITION AND MOTION CONTROL SOLUTIONS FOR YOUR SPECIFIC APPLICATIONS



## Hydraulic Stabilization Systems and Components

A comprehensive line of hydraulic stabilization legs and outriggers that are engineered for power and performance.



## Hydraulic Cab Tilt Systems

An extensive range of tilt cylinders, hydraulic pumps, hydraulic latches and hood assist units for cab tilting systems.

**POWER-PACKER®**  
PROGRESS IN MOTION

## ABOUT POWER-PACKER

Power-Packer engineers and manufactures a robust, innovative line of hydraulic position and motion control products that have become the gold standard in excellence for tilting, latching, leveling, lifting and stabilizing systems used in many of today's most demanding markets. We have headquarters in the Netherlands and the U.S., as well as manufacturing plants strategically located around the world. No matter your application, design challenge or geographic location, Power-Packer engineers can work with you to develop the right custom hydraulics solution to help you and your employees work smarter and safer.

Power-Packer Mfg.  
516 Hillcrest Drive  
Westfield, WI 53964  
800-745-4142  
[info@powerpackerus.com](mailto:info@powerpackerus.com)  
[powerpackerus.com](http://powerpackerus.com)